

AN INVESTIGATION OF MULTI-FUNCTIONAL SEMICONDUCTOR BISTABLE LASER

QIMING WANG, RONGHAN WU, SHIMING LIN, JIANMENG LI,
FEIKE XIONG and QUANSHENG ZHANG

*National Integrated Optoelectronics Laboratory,
Institute of Semiconductors, Chinese Academy of Sciences,
Beijing 100083, China*

The co-cavity two-section (CCTS) bistable semiconductor laser with DH and MQW structures has been investigated experimentally and theoretically in this laboratory. Many attractive functions, such as optical bistable switching, optical memory effect, high stability of single longitudinal mode emission spectrum in steady on state, high gain optical amplification, mode conversion effect on injecting signal light, long delay and abnormal relaxation oscillation, ultrafast light pulse generation are investigated in the device. As a high speed, single wavelength, novel laser light source, a monolithic MQW CCTS bistable laser with MQW EA modulator has been fabricated.

Introduction

In recent years, semiconductor bistable lasers have attracted many scientists and engineers with great interest for optoelectronic applications, in particular, in optical communication and optical signal processing.

It is well known that bistable lasers have many attractive novel functions from a viewpoint of optoelectronic applications. It is useful to develop the optical cross-connection network and digital signal processing technique with bistable switching and memory function in multi-medium communication and optical computing systems. The high power picosecond light pulse with high repetition rate generated in the device can be used to excite the optical soliton in fiber for fiber soliton communication. The high gain of optical amplification and the high stabilization of output wavelength by mode conversion effect on input signal light can be used to develop an all optical regenerator to be used in long distance fiber communication.

By utilizing the high stabilization of single longitudinal mode emission characteristics, it is possible to develop a dynamic single mode monolithic integrated laser source with high speed MQW EA modulator. Because its fabrication technology is relatively simple the application of this kind of integrated light sources for high speed optical transmission line has bright prospect. This paper reviews the progress in recent years in the research on semiconductor CCTS bistable lasers with either DH or MQW structure carried out in this laboratory.

Principle and Structure of Device

For effective optical bistability, there are two requirements that must be satisfied in the device. One is that the material of the active layer in the device must be a nonlinear saturable absorber, which provides a physical mechanism of nonlinear effect of the refractive index variation with the intensity of light. III-V compound semiconductor materials, especially quantum well structure materials, are the available medium for this requirement. The other one is the requirement of a strong positive optical feedback process in the device. For a conventional semiconductor laser, the Fabry–Perot (F–P) resonator or distributed feedback (DFB) structure are the most effective mechanisms to meet this requirement. So from the viewpoint of fabrication process, it is not too difficult to make a semiconductor bistable laser.

CCTS laser has a simple co-cavity two-section structure as shown in Fig. 1. The wafers for making the device with conventional DH structure or MQW structure are grown by LPE or MOCVD technology. Usually, the threshold currents of broad area (BA) lasers fabricated with these wafers are less than 2000 A/cm^2 and 500 A/cm^2 , respectively. By using selective etching and coating technology, the active layer of the device was divided into two sections, one is the gain section with current injection, the other is the absorption section without current injection. The lengths of the gain section and the absorption section are L_g and L_a , respectively. The total cavity length $L = L_g + L_a$ is usually about $300\text{--}400 \mu\text{m}$. The ratio L_a/L_g varies between $1/5$ and $1/3$. Ridge-waveguide, buried stripe waveguide and double channel stripe waveguide of $3\text{--}5 \mu\text{m}$ wide were used for lateral confinement. The etching depth for isolation of the two sections was just above the active layer for keeping a common optical cavity.

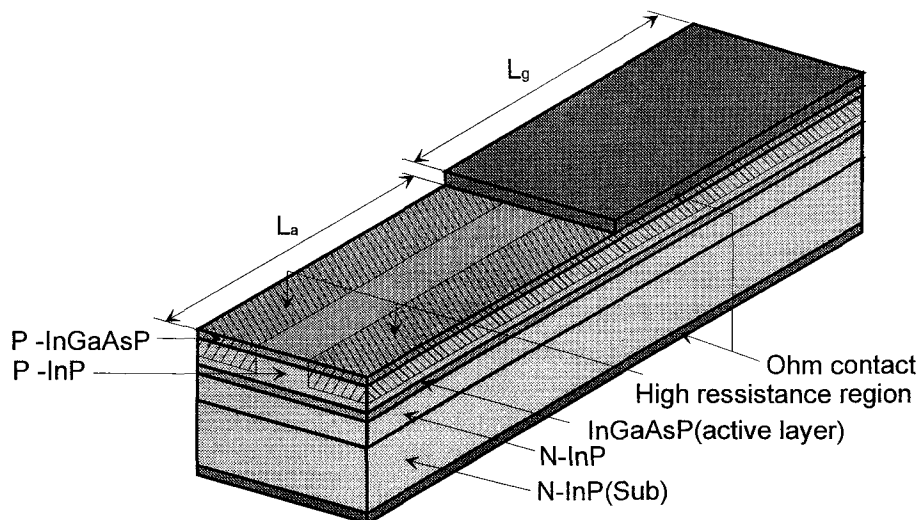

Fig. 1. The structure of a Common Cavity with Two Section (CCTS) bistable laser.

The ohmic contact materials coated on both sides of the device are the same as in the conventional semiconductor laser. The resonator of the device is a F - P structure. The electric-optical behaviors of CCTS bistable laser are described by the general electron and photon multi-mode rate equations,¹ which can be written as follows:

$$\frac{dn_1}{dt} = P_1 - Bn_1^2 - \frac{c}{n_{eff}} \sum_{\mu} g_{\mu}(n_1)s_{\mu} \quad (1)$$

$$\frac{dn_2}{dt} = P_2 - Bn_2^2 - \frac{c}{n_{eff}} \sum_{\mu} g_{\mu}(n_2)s_{\mu} \quad (2)$$

$$\frac{ds_{\mu}}{dt} = \left\{ \frac{c}{n_{eff}} [r_1 g_{\mu}(n_1) + r_2 g_{\mu}(n_2)] - \frac{1}{\tau_p} \right\} s_{\mu} + \beta_{\mu} B (r_1 n_1^2 + r_2 n_2^2) \quad (3)$$

where

$$r_1 + r_2 = \frac{L_g}{L} + \frac{L_a}{L} = 1, \quad P_1 = j_1/r_1qd, \quad P_2 = J_2/r_2qd$$

B	spontaneous emission coefficient
n_1, n_2	carrier concentration injected into the gain section and the absorption section, respectively
j_1, j_2	injection carrier densities
μ	longitudinal mode order
β_{μ}	coupling coefficient of μ th order mode to spontaneous emission
$g_{\mu}(n_1), g_{\mu}(n_2)$	gain coefficient of μ th order mode in the gain section and the absorption section, respectively
d	active layer thickness.

Assuming the linear gain function to vary with carrier concentration, we calculate the gain coefficient g using the parabolic interband transition with K-selection rule and the spontaneous radiation using the double molecular carrier recombination process. Equations (1)–(3) can be used to analyze the multi-function behaviors of the device either in steady state or transient state. We simplify the multi-mode rate equations to single-mode rate equation, and double molecular recombination process to single molecular recombination process and use the normalized rate equation. It will be more convenient to solve some problems.

For example, the following normalized simplified rate equations² are used to analyze the optical amplification characteristic in the device

$$\frac{dN_1}{dT} = J_1 - N_1 - G_1S \quad (4)$$

$$\frac{dN_2}{dT} = J_2 - N_2 - G_2S \quad (5)$$

$$\frac{dS}{dT} = C(r_1 G_1 + r_2 G_2 - 1)S + F + \beta(r_1 N_1 + r_2 N_2) \quad (6)$$

$$F = \frac{f}{n'\tau_p/\tau}, \text{ (} f \text{ is the injection photon density per second)}$$

$$T = t/\tau$$

$$J_i = j_i/(qdn'/\tau)$$

$$N_i = n_i/n'$$

$$G_i = \tau_p g_i$$

$$C = \tau/\tau_p$$

$$S = s/(\tau_p n'/\tau)$$

(n' is the transparent carrier density.)

High Stabilization of Single Longitudinal Mode Emission in Steady “On” State

The bistability and switching memory functions of the device under CW and pulsed operations have been observed, respectively. The turn-on threshold currents of the devices were in the range of 30 mA to 150 mA, which depends on both the threshold current density of BA laser fabricated from the same wafer and the ratio $k = L_a/L_g$. A typical experimental bistable hysteresis measured on an InGaAsP/InP DH CCTS laser is shown in Fig. 2. The turn-on and turn-off threshold currents $I_{\text{on}}, I_{\text{off}}$ were about 38 mA and 28 mA, respectively. So the width of the bistable current injection range ΔI is about 10 mA in this case. It depends on the ratio k , the larger k is, the wider is ΔI . If k is too small, ΔI will approach zero, it means that the CCTS laser turns to a Q -switching operation.

Figure 3 shows the switching memory effect of the device under pulsed operation. I_0 is the pre-bias injection current, which is just below the I_{on} . ΔI_0 is a narrow trigger current pulse with certain amplitude for turning on the device. In general, the turn-on response is about 0.1 ns. Even though the trigger pulse disappeared, the device still kept in the “on” state, until either the pre-bias injection current I_0 decreases below the I_{off} or an opposite trigger pulse with certain amplitude is applied at the device. Usually, the turn-off time is about 0.5 ns.

We have measured the emission spectrum in steady state in a wide injection current range (inside or outside the hysteresis region). It is very interesting that the single longitudinal mode emission of the same wavelength can be sustained as shown in Fig. 4. The relative deviation from the central wavelength is less than 10^{-5} . Being limited by spectroscopic resolution the half spectral linewidth measured is about 1.3 Å. It can be considered that this precise emission wavelength stabilization results from zero value gain locking effect of the absorption region.³ However, a time delay exists in this gain locking. The result of theoretical analysis¹ based on multi-mode rate equations is given in Fig. 5. It can be seen that once applying an injection current to the device following the switch on at the starting point in time domain the emission spectrum is multi-mode. With time subsequently increased for several

ns, the multi-mode emission transfers gradually into a single mode. It is well in agreement with the experimental results obtained.

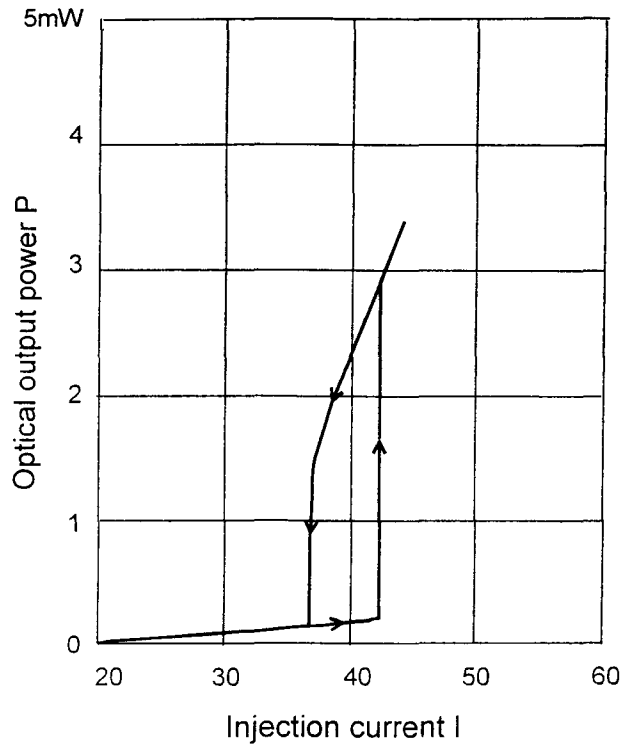

Fig. 2. Bistable hysteresis of A CCTS Laser (No. OB-193) without pre-bias in absorption section

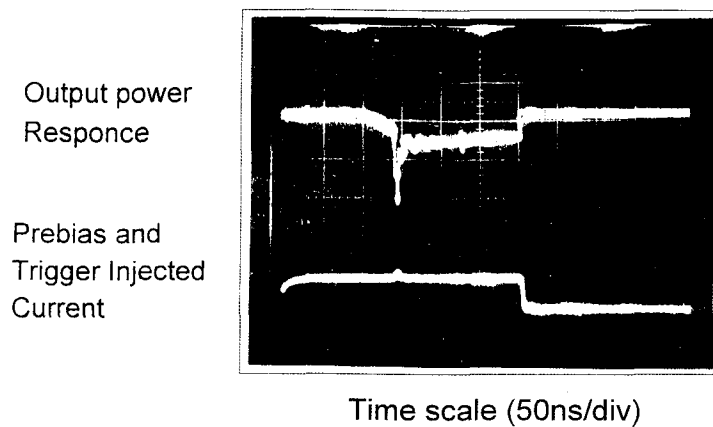

Fig. 3. Optical memory switching function from CCTS bistable laser.

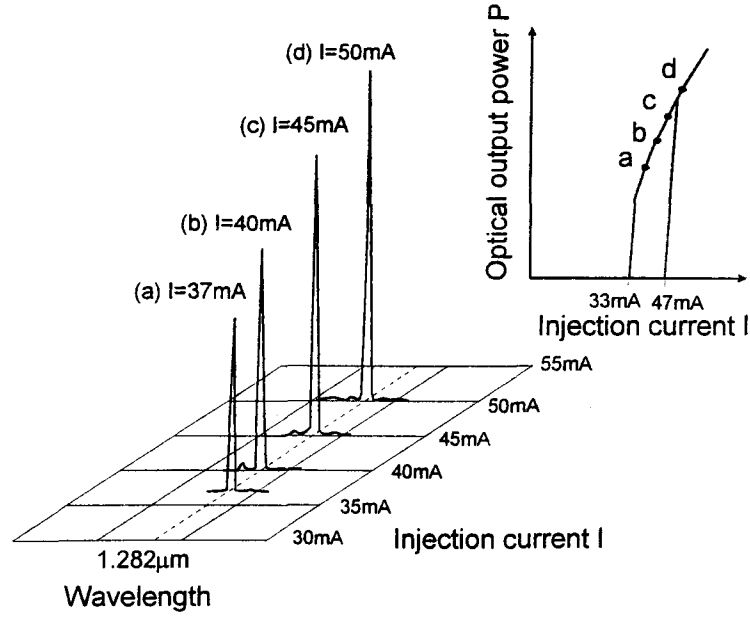

Fig. 4. Single mode emission spectra of CCTS OB laser at “on” steady state in the bistable loop range (37 mA–50 mA).

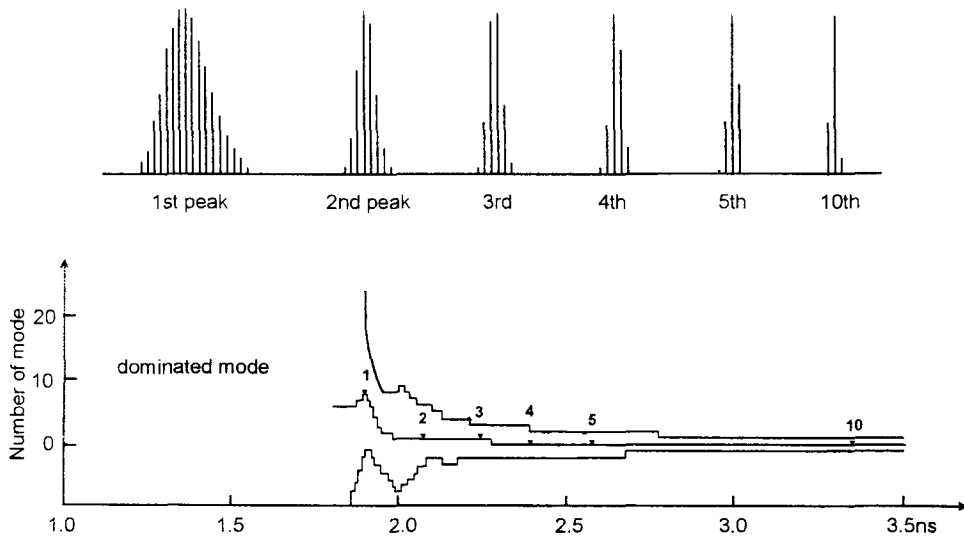

Fig. 5. The mode competition and spectrum width variation with time during switching on in a CCTS bistable laser.

Transient Response and Ultrafast Light Pulse Generation

CCTS bistable semiconductor laser works in an inhomogeneous injection mode with a nonlinear absorber in the active layer. It brings the device a long time delay and a strong Q -switching effect in comparison with that of a conventional homogeneous semiconductor laser. The transient response behaviors in a bistable laser are more complex than those of conventional DH lasers⁴ as shown in Fig. 6(a)–(f). Figure 6(g) shows the waveform of injection current with the pulse duration of 25 ns. The transient responses at different pulse injection levels from 140 mA to 200 mA are quite different.

A long delay is one of the features of these devices, which can be controlled from ns to μ s by adjusting the injection pulse amplitude and the level of pre-bias.

Another feature is that the output power of the first pulse of relaxation oscillation peak is much higher than that of an ordinary DH lasers, and the pulse can drop

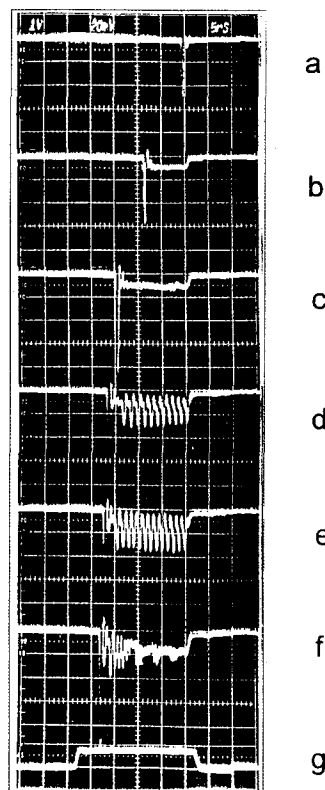

Time Scale (5ns/div)

Fig. 6. Photograph of the transient response of CCTS bistable laser at different injection levels ((a) 140 mA; (b) 160 mA; (c) 170 mA; (d) 180 mA; (e) 190 mA; (f) 200 mA).

down to zero caused by a strong Q -switching effect. So it provides an opportunity for us to generate a high power ultrafast light pulse with CCTS lasers. By cutting out the first light pulse of relaxation oscillation with an external electrical circuit, a 10 ps FWHM light pulse with 10 mW output power can be realized as shown in Fig. 7, measured with a streak camera. It is an available light source for exciting the optical soliton in fiber transmission lines.

It can be seen from Fig. 6(d)–(e) that the strong double branch self-sustained pulsation is present when the injection currents level exceeded 170 mA. As pointed out in our early work,⁵ both the self-sustained pulsation and the bistable behavior are closely related to the nonlinearity of the gain coefficient. When the gain coefficient possesses a stronger nonlinearity, the bistability will disappear and strong self-sustained pulsation will take place.

In this case, the high level injection must cause a strong nonlinearity of gain coefficient. With further increase of the injection level of up to 200 mA, the optical chaos behavior occurs in the output power. It also provides an opportunity to develop a small size semiconductor optical chaos generator with the CCTS laser.

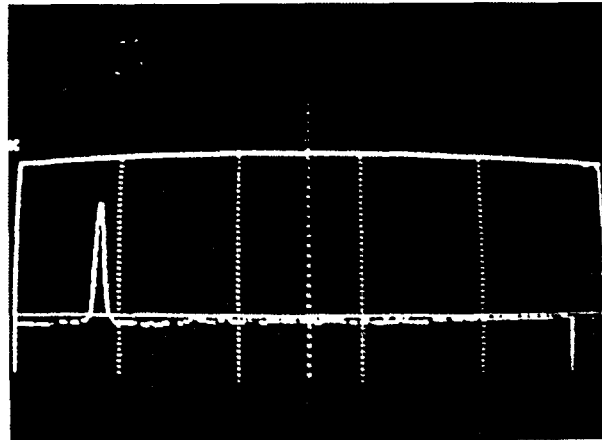

Time Scale (50ps/div)

Fig. 7. Light pulse trace in a streak camera generated from a CCTS bistable laser.

High Gain Optical Amplification and Mode Conversion on Injecting Signal Light

A bistable CCTS laser under a proper pre-bias can also be turned on by an injected light pulse along the cavity axial direction. So a weak optical signal can be amplified by a bistable laser. The gain will depend on the pre-bias condition. The closer the pre-bias injection approaches the turn-on threshold, the higher is the gain.

A simulation result of the amplification characteristics in the device with rate equation (4)–(6) is shown in Fig. 8.

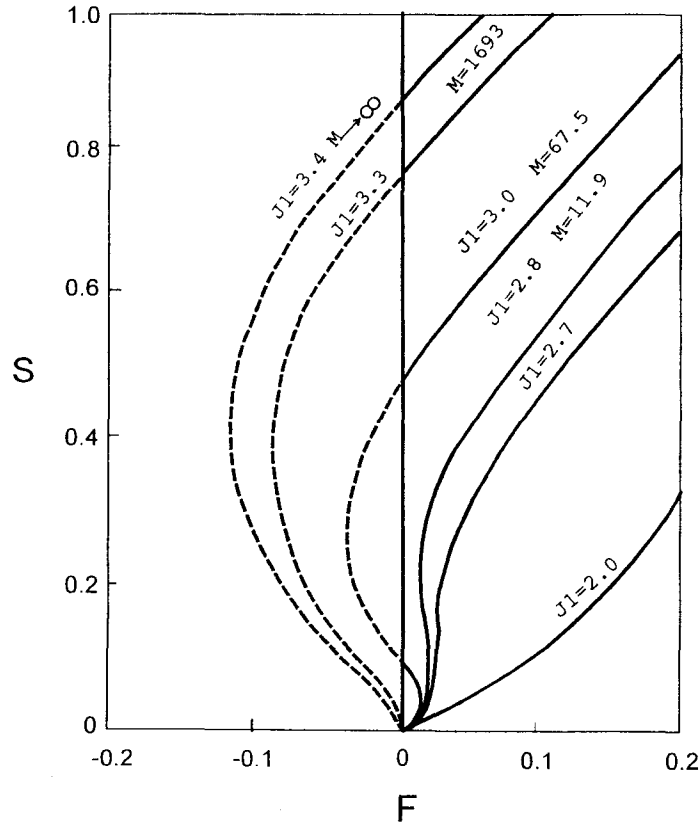

Fig. 8. A simulation of amplification (S-F) characteristics of CCTS OB LD operating with an axial light injection.

Figure 9 shows a typical experimental result of the amplification characteristics in the device.⁶ The turn-on threshold current I_{on} and bistable injection current range ΔI of the CCTS bistable laser operated as an amplifier is about 131.5 mA and 7.5 mA, respectively.

As can be seen from the figure, the pre-bias conditions not only determine the gain value but also influence the amplification characteristics. As the pre-bias injected current exceeds 127 mA, the optical amplification characteristics are observed. Besides, even though the injected signal light is off, the device remains at the high output power level. The signal light power coupled into the cavity is estimated to be one microwatt and the output light power from the device is in the order of milliwatts. Therefore the gain is about 10^3 under the 130 mA

pre-bias current. In the case of pre-bias current below 127 mA, the amplification behaviors are rather different from the typical characteristics. It may be caused by the inhomogeneous distribution of the injected light along the cavity, owing to the absorption of injected light in this case.

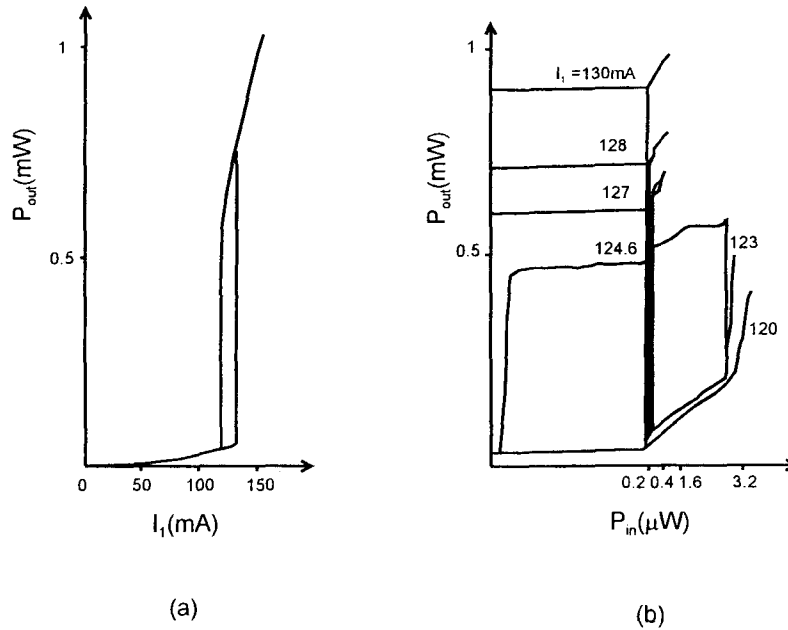

Fig. 9. Optical amplification of a CCTS OB LD operated at different pre-base injection level.

It is very interesting that even though the injected external signal light has more complex multimode spectrum while the amplified output light is always a single longitudinal mode emission in steady state⁷ as shown in Fig. 10. Figure 10(b)(I) shows a multi-mode spectrum of the external injection light, and Fig. 10(a) shows the single-mode emission spectrum from the CCTS bistable laser. Using this device as an optical amplifier, the output spectrum of the amplified injected signal light with multimode will turn to the single mode emission spectrum.

Because the physical process of this amplification is attributed to the strong Q-switching effect, the spectrum characteristic of the regenerated output light will only depend on the operation condition in the device, despite the mode character of injected signal light.

It may be very interesting to develop an all optical high gain regenerator for high capacity optical fiber communication applications. It can be used to improve the dispersion effect in the fiber.

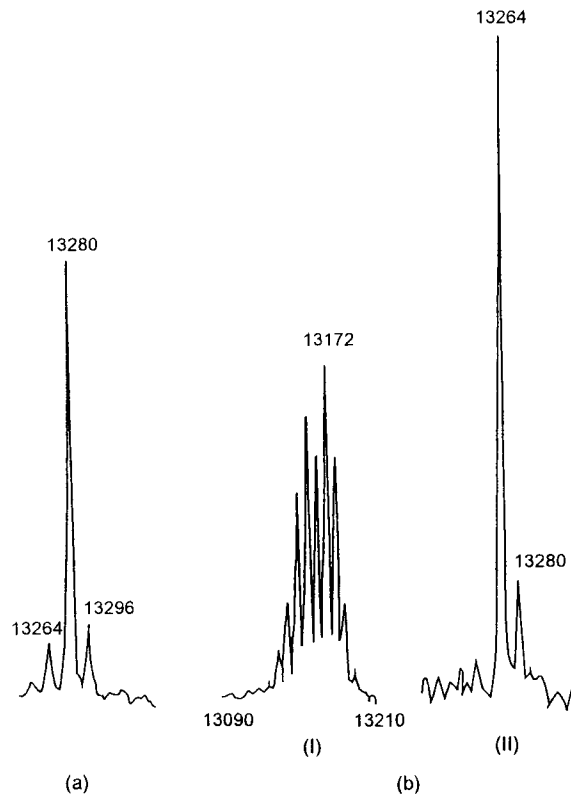

Fig. 10. Mode conversion on an injected signal light by a CCTS bistable laser operated as an optical amplifier.

Quantum Well CCTS Bistable Laser and Its Monolithic Integration with EA Modulator

It is well known, quantum well materials are suitable for fabrication for low threshold current, high speed and narrow emission spectra linewidth semiconductor lasers, that are applicable for large scale photonic integration.

It is also well known, quantum well materials, as a multifunction material, have excellent compatibility for integrating different kinds of semiconductor photonic devices and electronic device on the same wafer. It is very helpful to develop monolithic photonic and optoelectronic integration with rather simple process technology. We propose to develop a monolithic integration with MQW CCTS laser and EA modulator as a high speed, dynamic single frequency integrated light source.⁸

In order to demonstrate this idea, pin structure MQW wafers were grown on n^+ GaAs substrates by LP-MOCVD. The i -region consists of two unintentionally doped graded layers and a MQW active waveguide layer. The MQW layer consists of eight

GaAs quantum wells of 120 Å thick and seven $\text{Al}_{0.3}\text{Ga}_{0.7}\text{As}$ barriers of 100 Å thick. The thickness of the graded layer is about 1000 Å, and the composition x varies from 0.45 to 0.3. The graded layer contributes to increase the optical confinement factor of lasers and modulators and acts as buffer spacer between the undoped quantum well layer and heavily doped electrode layer. Broad-area MQW lasers were fabricated. The threshold current is less than 600 A/cm².

Using the MQW wafer, we fabricated CCTS lasers. The length of gain section and absorption section is 200 μm and 100 μm, respectively. High resistance isolation up to 1 MΩ between the two regions was formed by channel and ion implantation of H₂ and O₂. No bistable characteristics occurs when no bias is applied to the absorption region because the lasing photon energy of the quantum well laser falls in the band edge where the absorption coefficient is very small. The Q modulation degree of the CCTS laser is very small and there is no zero value gain locking. The emission spectrum of the CCTS laser measured has multiple longitudinal mode structure as shown in Fig. 11.

When a negative bias is applied to the absorption region of the CCTS laser, the absorption edge shifts to longer wavelengths by the quantum confined Stark effect, resulting in remarkable increase of absorption and a bistable hysteresis characteristics of the CCTS laser lasing output is observed. The optical emission spectrum immediately turns into steady state single longitudinal mode as shown in Fig. 12. The spectral linewidth measured is 0.88 Å.

We have made a MQW EA electro-optic modulator with the same quantum well wafer. The lateral waveguides of both laser and modulator have double channel stripe structure with 3–4 μm width in order to ensure fundamental transverse mode operation. The modulator length was designed to be 240 μm. Owing to the red-shift effect of the electrical field on excitation absorption in quantum well materials, i.e., quantum confined stark effect (QCSE) is much stronger than the Franz–Keldish effect in bulk materials. A high sensitivity of up to 2 meV/V-cm can be obtained.

Within the range of V_b from 0 to –10 V, the absorption edge red-shift resulted from QCSE has good linearity with an average shift of 70 Å/V indicating that this kind of material is very suitable for modulators.

The modulation characteristics for TE polarized mode at five wavelengths ranging from 8630–8820 Å were measured. The results are shown in Fig. 12. For a 8720 Å wavelength, under 2 V bias the maximum modulation depth reaches 22.4 dB and for longer wavelengths, the results are better. The distortion under 1 GHz operation of this MQW modulator is small.

According to the results mentioned above, a novel monolithic MQW modulator/CCTS OB laser light source has been proposed and fabrication of this device is underway in our laboratory. This kind of photonic integrated device has the advantages of a simple structure, simple technology and ability of sustaining single longitudinal mode operation at high speed above Gb/s.

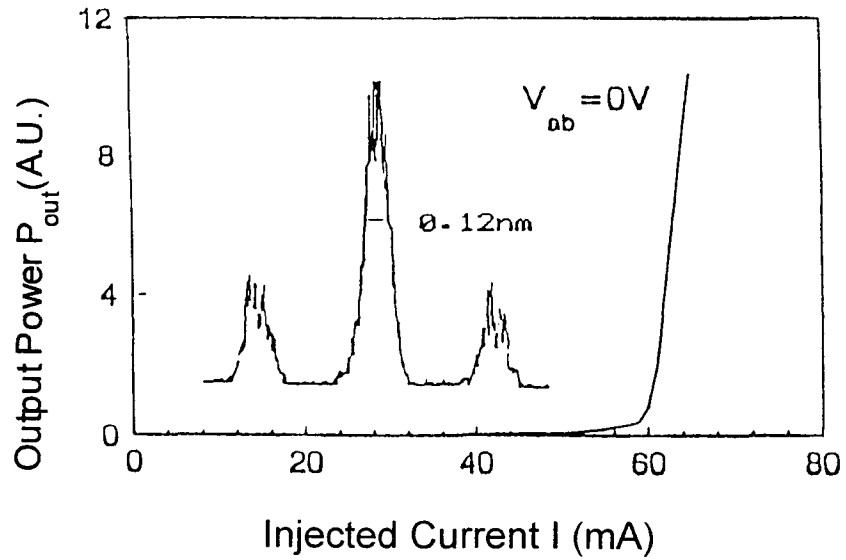

Fig. 11. Longitudinal emission mode from a CCTS MQW bistable laser without pre-bias in absorption section.

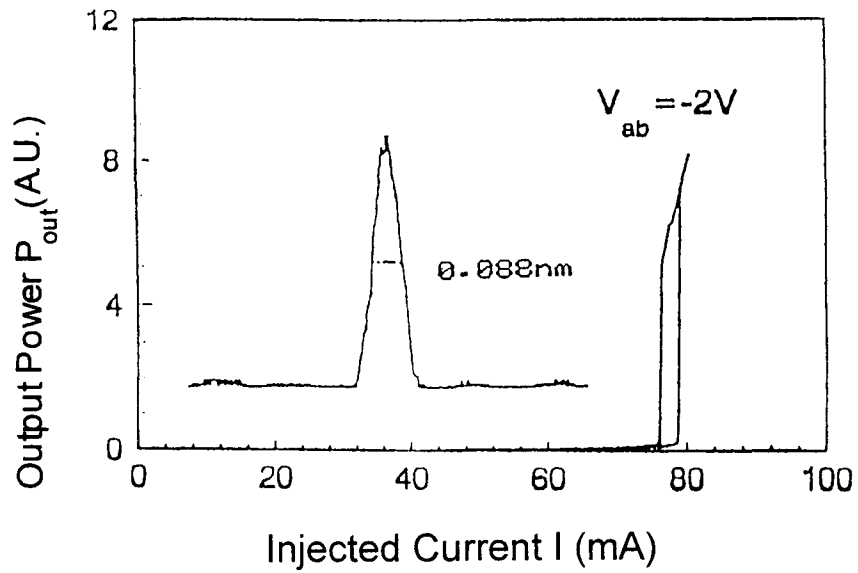

Fig. 12. Longitudinal emission mode from a CCTS MQW bistable laser with opposite pre-bias in an absorption section.

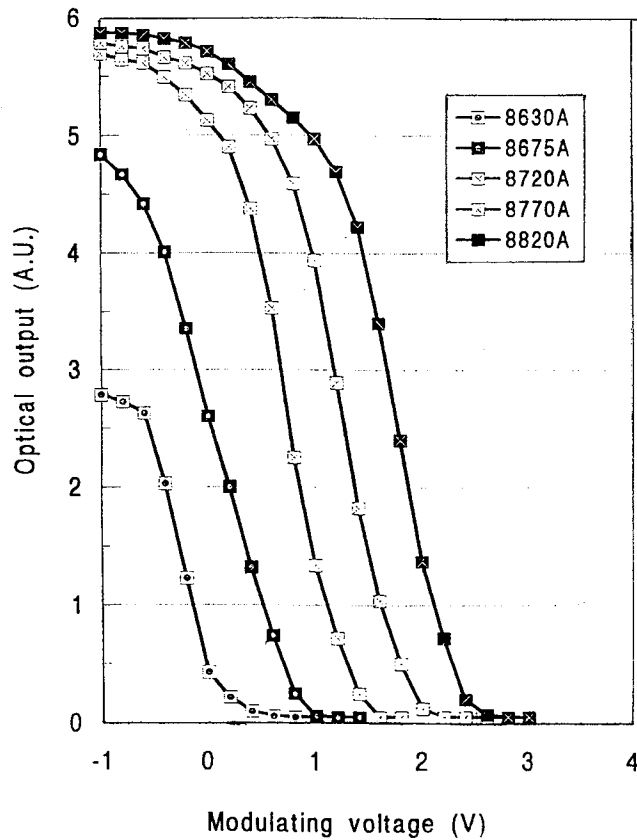

Fig. 13. Modulating characteristics of an MQW electro-optical modulator.

Meanwhile, by changing the negative bias on the absorption region, the emission peak wavelength can be tuned. For these reasons, this device is believed to be reliable and cheap lasing light source suitable for wavelength division multiplexed optical communication system.

Conclusion

A novel semiconductor bistable laser with a simple structure and multifunctions is described. It promises to be useful in high capacity and high speed optical communications for transmission, regeneration and cross-connection. Besides, CCTS laser used as a bistable active device with optical logic functions may play a key role in developing optical digital processing and optical computing technique.

Integration of the CCTS bistable laser with other photonic devices will give it even more opportunity to show its advantage in multi-functions and expand its scope of application.

Quantum well structure materials will play an important role in the development of this interesting field.

References

1. S. W. Wang, Q. M. Wang, and S. M. Lin, "Investigation of bistable characteristics of a semiconductor laser with single cavity and double contacts", *Chinese J. of Semiconductors* **7**, 2 (1986) 136–146.
2. Q. M. Wang and J. M. Li, "Computer simulations for a common-cavity two section (CCTS) bistable laser", *Optical and Quantum Electronics* **19** (1987) 83–91.
3. Q. M. Wang, L. D. Zhu, and Q. P. Cao, "A bistable InGaAsP/InP DH lasers with inner modulation on Q -factor by proton bombardment", *ACTA Physica Sinica* **38**, 8 (1985) 1102–1106.
4. Q. M. Wang, R. H. Wu, J. H. Zhao, W. X. Liu, and Q. S. Zhang, "Experimental investigation of static and dynamic characteristics in GaAs/AlGaAs, CCTS OB laser", *Chinese J. of Semiconductors* **11**, 1 (1990) 28.
5. S. W. Wang, Q. M. Wang, and S. M. Lin, "Stability analysis of semiconductor bistable lasers", *IEEE J. of Quantum Electronics* **QE-23**, 16 (1987) 1033–1038.
6. Q. M. Wang, R. H. Wu, J. M. Li, and H. Wu, "Experimental results for a CCTS bistable DH laser under optical injection", *Chinese J. of Semiconductors* **9**, 1 (1988) 108.
7. Q. M. Wang, R. H. Wu, S. M. Lin, J. M. Li, J. H. Zhao, W. X. Liu, Q. S. Zhang, and S. W. Wang, "Investigation of semiconductor CCTS bistable laser diodes", *Int. J. of Optoelectronics* **7**, 1 (1992) 85–90.
8. Q. M. Wang, F. K. Xiong, W. Z. Cao, R. H. Wu, S. M. Lin, and Q. S. Zhang, "Novel monolithic MQW modulator/co-cavity two-section optical bistable laser light source", *Int. Symp. on Physical Concept and Materials for Novel Optoelectronics Device Application II*, Trieste, Italy, May 1993, P727–731.